

“BH” VIBRATORS

OPERATING INSTRUCTIONS

MOUNTING ON RECTANGULAR HOPPERS (FLAT SURFACE) T – SLOTTED MOUNTING PLATE

1. Determine proper mounting location according to page one. Assure a mounting angle greater than 20 degrees unless ‘SP’ type.
2. Weld plate (A) to hopper (Skip weld and fill full circumference) with low hydrogen rod.
3. Insert bolts (B) in slots and place vibrator (C) over bolts.
4. Install and thread lockwasher (if included) and nut (D). Tighten securely.
5. following air supply connection, operate vibrator for short period and retighten all fasteners.

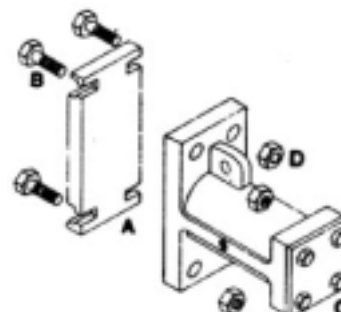

NOTE: Safety cable recommended

MOUNTING ON CONICAL HOPPERS (CURVED SURFACE) CHANNEL MOUNTING PLATE

1. Determine proper mounting location according to page one. Assure a mounting angle greater than 20 degrees unless ‘SP’ type.
2. Install mounting bolts (B) through holes in the mounting channel (A).
3. Weld both channel legs to hopper (skip weld and fill full length) with low hydrogen rod.
4. Install vibrator © over mounting bolts.
5. Install and thread lockwasher (if included) and nut (D). Tighten securely.
6. following air supply connection, operate vibrator for a short period and retighten all fasteners.

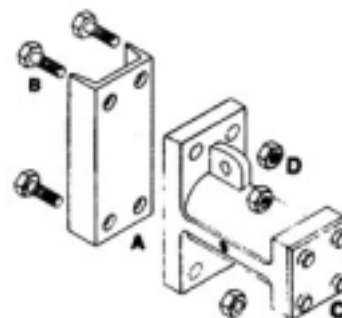

NOTE: A backing plate may be necessary to reinforce bin wall. See Bulletin 4000.202 for required thickness.

AIR CONTROL CONNECTION

1. Install air control package (see Diagram)
2. Fill the lubricator with SAE 10, or lighter, non-detergent oil. (See Bulletin 4000.503).
3. Set the pressure regulator to 50 PSI (see FRL instructions).
4. Open valve
5. Adjust the Lubricator to approximately 10 drops of oil per minute (see FRL instructions and Bulletin 4000.503).
6. Allow vibrator to operate for five minutes
7. Inspect and re-tighten **ALL** mounting fasteners and air line connections.
8. Adjust Air Regulator for the lowest pressure which will give the desired material flow performance. (Not to exceed 60 psig)
9. Periodically fill oil reservoir to assure lubrication for the vibrator.

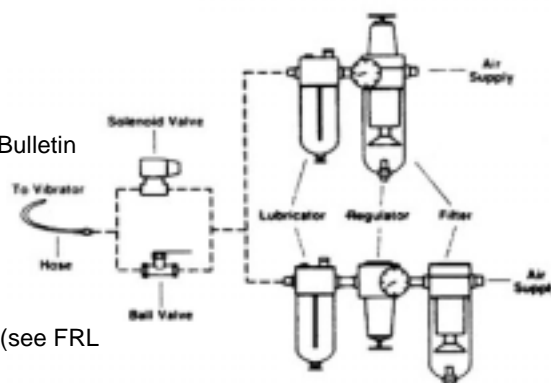

NOTE: All vibrators must be installed with an inline lubricator. All units must also be installed with a Filter and Regulator.

NAVCO[®]

MAINTENANCE & TROUBLE-SHOOTING

MAINTENANCE:

1. Check Automatic Lubricator and add SAE 10 (or lighter) oil if low.
2. Check to see that air pressure is correctly set for most efficient operation
3. If filter is installed in system, drain to remove contaminants (water, scale, etc)
4. Check all air connections and tighten if necessary.
5. Tighten any bolts that may have loosened over a period of time (maintenance/plant shut-down) be certain that vibrator is well lubricated.

TROUBLE-SHOOTING

1. Vibrator will not start:
 - a. Check to see that quick-opening valve is properly installed
 - b. Vibrator should be within 5 feet of operating valve
 - c. Be sure vibrator has adequate air pressure and volume available.
 - d. Check for broken or missing spring on horizontal mount (SP) units.
2. Vibrator is sluggish and slow to start:
 - a. Check for adequate lubrication.
 - b. Check for leaking air line or defective operating valve.
 - c. Check air supply for pressure and volume.
 - d. Scale or other contaminants may need to be removed from interior.

CONDITIONAL WARRANTY

All NAVCO Vibrators are warranted for twelve (12) full months from the date of purchase. NAVCO will repair or replace any portion of the vibrator proven defective in quality or workmanship. (See Bulletin 4000.508).

The following conditions will determine warranty credit:

1. All vibrators must be installed with an inline lubricator.
2. All vibrators must be used with an inline filter and regulator.
3. All vibrators must be properly installed according to instructions.
4. All vibrators must be free of signs of abuse, misuse, or contamination of chamber by foreign material.
5. Vibrators must **NOT** be disassembled by customer.

To obtain credit, vibrators must be returned to NAVCO freight "prepaid." NAVCO will prepay return freight on warranty vibrators. Non-warranted repairs will be returned "collect."

NAVCO will provide a list of repairs and an estimate of repair cost. Repairs are made on acceptance of this cost.



FOR MORE INFORMATION CALL: 1-800-231-0164 or 832-467-3636
11929 Brittmoore Park Drive – Houston, TX - 77041